



Cartridge filter system offers wide range of flow capacities & contaminant holding capacities. Cartridge filter housing diameters can accommodate around 1 to 500 cartridges. Cartridge filters are normally used as polishing filter in almost all process industries. Cartridge filter is constructed of filter housing, filter cartridges, tube sheet, positive sealing arrangement for cartridge depending upon type of cartridge & choice of end connections. Positive sealing arrangement for cartridge filter assures no particle migration or fiber migration, even after high differential pressures.

Operation

Contaminated fluid enters the housing and is distributed evenly around the filter cartridges. Filtration takes place from outside to inside. Solids are collected on the outside of filter cartridges & clear filtrate is collected at outlet.

Features & Benefits

- Low pressure drop
- High dirt holding capacity
- Zero hold up design
- Permanently piped housing are opened without special tools and without disturbing the piping
- Machined cover gasket groove provide positive O-Ring sealing
- Easy to clean
- In-line inlet and outlet high flow rates
- Positive sealing arrangement to avoid bypassing
- Suitable for double open end (DOE), Code 7 (226 O-Ring) & 222 O-Ring type filter cartridge
- Accommodates 10", 20", 30", 40", 50" & 60" long filter cartridges.
- End connections of 3/4" to 24" pipe
- V posts or threaded center posts
- Quick opening tri clovers design
- Easy to operate & low maintenance
- Low down time
- Flow rate up to 2000 m³/hr & more
- Customized design available
- Housings are permanently piped
- All housings made from SS 316 L, SS 316 & SS 304 are mirror polished & electro polished to resist adhesion of dirt and scale
- Carbon steel housings are sand blasted, epoxy coated & finally painted with two coats of synthetic enamel
- ASME code stamp available
- Duplex / Triplex / Jacketed cartridge filter unit designs are available
- High temperature & high pressure designs are available

Special Options

- Sanitary fittings and construction
- High pressure rating
- Housings of alloy steel
- Steam jackets
- Special outlet locations
- Optional cartridge sealing methods for 226, NPT, etc.
- High temperature gasket designs

Technical Specifications

Sizes (Cartridge filter housings suitable for)

- 1 No. To 500 Nos. Of Cartridges in Single Housing
- 2", 2.5", 4", 6" & 8" Diameter of Cartridge
- 10", 20", 30", 40", 50" & 60" Length of cartridge

Flow Rate

- Capacity: Up to 2000 m³/hr & more

Material of Construction

- SS 316L • SS 316 • SS 304 • CARBON STEEL (ALL GRADE) • MILD STEEL • ALLOY METALS
- Super Duplex, Duplex stainless steel 2205
- POLYPROPYLENE • LEAD LINING on any metal
- RUBBER LINING on any metal
- TEFLON LINING on any metal
- TEFLON coating on any metal

Cartridge filter housing suitable for filter cartridges of

- Double Open End (DOE) Type
- Code 7 (226 O Ring) Design
- Code 3 (222 O Ring) Design
- NPT Threaded Connection Type

Gasket / O Ring Material

- Neoprene • Spiral Wound
- Nitrile • CAF
- Silicone
- Viton
- Buna N
- EPDM
- PTFE
- Spiral wound
- CAF

End connections available

- NPT / BSP Threaded
- Flanged Table E / Table F
- ANSI B 16.5 Flanged
- DIN Standard
- Tri Clover Adaptors
- SMS /Dairy End Connection

Applications

• Pharmaceuticals	• Petroleum Derivatives
• Water Treatment	• Coolants
• Paints & Inks	• Food & Beverages
• Bore Well water	• Dairy
• Dyes & Intermediates	• RO Pre filtration
• Processing Chemicals	• & Many More

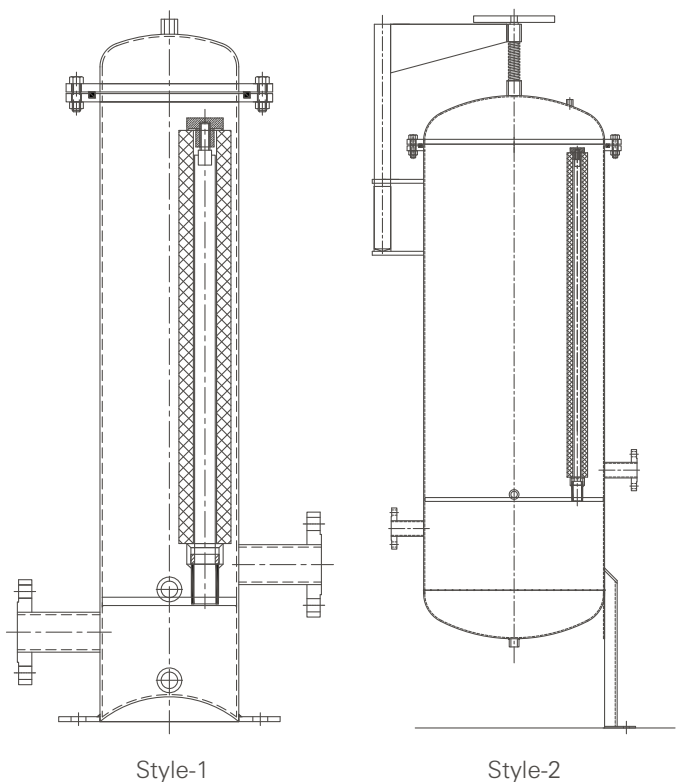

Style-1

Style-2

Hygienic Filter Housing



Hygienic filter housing is manufactured from 316 stainless steel of the highest quality. These are suitable for a variety of liquid filtration applications designed to fit standard 222 'O' Rings & 226 'O' Ring cartridges. They have an integral bayonet locator providing an efficient seal between housing and cartridge. Depending on their type hygienic filter housing is available in 1, 3, 5 and 12 round configurations and in 10", 20", 30" and 40" length cartridge. Its hygienic design ensures low product hold up & reduces product loss.

Operation

Contaminated fluid enters the housing and is distributed evenly around the filter cartridges. Filtration takes place from outside to inside. Solids are collected on the outside of filter cartridges & clear filtrate is collected at outlet.

Features & Benefits

- Integral cartridge location
- Low product hold-up
- Easy to clean
- Steam sterilisable
- EPDM seals / silicone
- Quick release housing clamp
- Hygienic clamp pipe fittings
- Full range of sizes

Hygienic filter housing can be steam sterilized in-situ in accordance with cartridge parameters. All housings are supplied with support legs, enabling free standing or in-line installation.

Technical Specifications

• Material of Construction	SS 316L (Stainless Steel SS 316 L)
• Connections	Hygienic clamp type
• Surface treatment	Mirror polished & electro polished
• Cartridge fitting	222 'O' ring / 226 'O' Ring (bayonet fit)
• Maximum operating pressure	7 BARG (102 psig)
• Housing closure seal	EPDM / silicone 'O' Ring for single cartridge, EPDM / silicone square O Ring for multi cartridge

Additional Features

- Alternative connection types are available such as Table-E, Table-F, ASA 150#, and DIN.
- Standard seal material is EPDM. Silicone and Viton options are also available.
- A full range of pipe accessories are available such as clamps, seals, ferrules and hose liners.

Applications

• Food
• Dairy
• Beverage
• Electronics and Pharmaceutical Industries

